

Harmonic Sliding Analysis Problems

VLADIMIR Ya. KRAKOVSKY

Ph.D. in Eng., Senior Researcher

Speech Science & Technology Department

International Research-Training Centre for Information Technologies and Systems

40 Academician Hlushkov Avenue, Kyiv 03680 Ukraine

Phone: +380-44-266-4563, Fax: +380-44-266-1570

E-mail: vladimir_krakovsky@uasoiro.org.ua

Abstract — Harmonic sliding analysis (HSA) is a dynamic spectrum analysis [1] in which the next analysis interval differs from the previous one by including the next signal sample and excluding the first one from the previous analysis interval. Such a harmonic analysis is necessary for time-frequency localization [2] of analysed signal given peculiarities. Using the well-known Fast Fourier transform (FFT) is not effective in this context. More effective are known recursive algorithms which use only one complex multiplication for computing one harmonic during each analysis interval. Author improved one of such algorithms so, that it became possible to use one complex multiplication for computing two, four and even eight (for complex signals) harmonics simultaneously [3-5]. Problems of realization [6] and application of the harmonic sliding analysis are considered in the paper.

Index Terms — Harmonic analysis, harmonic sliding analysis, dynamic spectrum analysis, recursive algorithms, sliding spectrum algorithms & analyzers, instant spectrum algorithms & analyzers, algorithms for instantaneous spectrum digital analyzers, multichannel filter.

I. INTRODUCTION

Depending on the signal presentation forms, HSA may be implemented with analog, digital or discrete-analog spectrum analyzers. Narrow band analog filters set permits to implement HSA at some points of the frequencies working band. However, such analyzers are usually designed to analyze power spectrum and they are not capable to analyze phase spectrum and complex spectrum Cartesian constituents. This circumstance restricts their application [7]. The spectrum analysis discrete-analog method is based on using of the signal discrete copy which is being presented with an uncrossed pulse sequence, magnitudes of which are altered in accordance with the instant sample values of the analyzed signal. This type analyzer permits to do the spectrum analysis with quality and quantity compatibility conditions and the information completeness condition as well [7] and they may be adapted for HSA [8, 9]. Spectrum digital analyzers [1] are the most popular.

There are two HSA spectrum varieties: the first one is resulted when the reference function origin is matched with the interval analysis origin. This spectrum variety is advisable to name as a sliding spectrum [10]. In many practice instances (e.g., speech recognition) there isn't need to such matching. This second spectrum variety is advisable to name as an instant spectrum [10]. These spectrum variety algorithms and devices are considered below.

II. SLIDING SPECTRUM ALGORITHMS & DEVICES

While using discrete procedures it is possible to result experimentally only discrete sliding spectrum samples in time t and in frequency w :

$$F_q(p) = \frac{1}{N} \sum_{k=q-N+1}^q f(k) W_N^{-p[k-(q-N+1)]}, \quad p \in \overline{0, P-1}, \quad q = 0, 1, 2, \dots, \quad (1)$$

where q is an analysis interval index, k is a signal sample index in the limits of the sliding window $k \in \overline{q-N+1, q}$, N is the size of the processing extract, $F_q(p)$ are complex spectrum samples determined at the frequency $p\Delta\omega$ at the instant $q\Delta t$, $f(k)$ is the analyzed signal sample value at the instant $k\Delta t$, W_N^{-pk} is the complex reference coefficient symbolic representation $\exp\left[-j\frac{2\pi}{N}pk\right]$, Δt and $\Delta\omega$ are discrete intervals by time and frequency, respectively, determined from condition of information completeness [7], P is the sliding spectrum $F_q(p)$ spectral samples determined number.

The functional (1) direct computing requires NP complex multiplications and $(N-1)P$ additions. FFT [11] reduces this number by $N/\log_2 N$. The further reduction is possible by recursive algorithm [12]:

$$F_q(p) = \left\{ F_{q-1}(p) + \frac{1}{N} [f(q) - f(q-N)] \right\} W_N^p, \quad p \in \overline{0, P-1}, \quad q = 0, 1, 2, \dots \quad (2)$$

Transforms (1) and (2) are identical by the end results. But essential is the computer requirements (number of complex multiplications) are considerably lower while using (2) than (1). If while sliding analysis of size N interval in the last case it is necessary N complex multiplications for computing of each spectrum sample ($\log_2 N$ if FFT is used), while using (2) in the same conditions it is necessary only one complex multiplication. This circumstance has determined interest to sliding spectrum analyzers using (2).

The spectrum analyzer functional diagram implementing the algorithm (2) is shown in Fig. 1. The following symbols are used in the diagram: ADC is the analog-digital converter, DR is the delay register, SU is the subtraction unit, AD is the adder, WU is the weighting unit, MU is the multiplier, RAM is the random-access memory; $f(t)$ is the analog input signal; f_q are digital readouts of the signal $f(t)$; f_{q-N} are the readouts f_q delayed by N steps; Δf_q are the readouts of the difference signal $f_q - f_{q-N}$; W_N^p are the readouts of the weighting function $\exp\left(j\frac{2\pi}{N}p\right)$; $F_q(p)$, $F_{q-1}(p)$ are the sliding spectrum readouts in the current and the preceding steps, respectively.

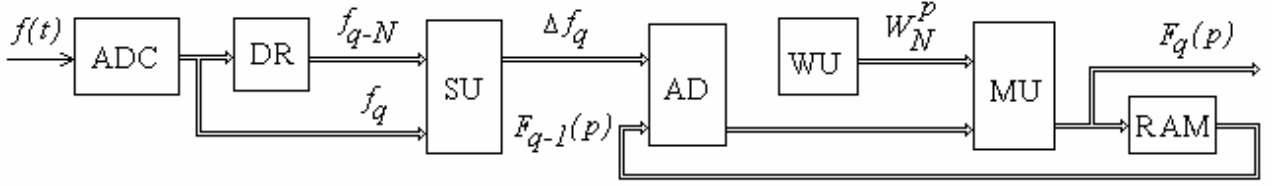

Fig. 1

Peculiarities of analyzers [13-15], which implement (2), are given in [16]. The algorithm (2) stability is achieved by the appropriate rounding of twiddle factor constituents under whom the factor modulus is not exceeding unity [17]. The constituents' word size should be by a half of the sliding steps number binary logarithm more than the signal samples one [18]. For unlimited sliding steps number it is possible to use the technical decision described in [19]. While using algorithm (2) the reference function is always matched with the analysis interval origin thereby ensuring a matched filtering [20-22].

III. INSTANT SPECTRUM ALGORITHMS & DEVICES

To yield an instant spectrum

$$F_q(p) = \frac{1}{N} \sum_{k=q-N+1}^q f(k) W_N^{-pk}, \quad p \in \overline{0, P-1}, \quad q = 0, 1, 2, \dots \quad (3)$$

it is possible to use more simple recursive algorithm, described in [23, 24].

$$F_q(p) = F_{q-1}(p) + \frac{1}{N} [f(q) - f(q-N)] W_N^{-pq}, \quad p \in \overline{0, P-1}, \quad q = 0, 1, 2, \dots \quad (4)$$

This algorithm is always stable and the twiddle factors W_N^{-pq} word size is the same as the signal samples one. Moreover, it's possible to make the required matching with an additional multiplier and a complex conjugate device [10]. In [25, 26] it's described devices that implement this algorithm using the conveyer mode.

The spectrum analyzer functional diagram implementing algorithm (4) is shown in Fig. 2, where $\Delta F_q(p)$ are the increments of the spectrum readouts $(1/N)\Delta f_q W_N^{-pq}$.

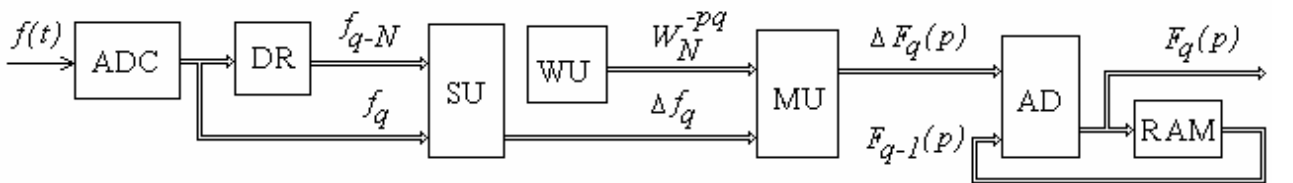

Fig. 2

The spectrum analyzer functional diagram implementing algorithm (4) and making the mentioned matching is shown in Fig. 3, where CCU and AMU are the complex conjugate device and additional multiplier, respectively [10].

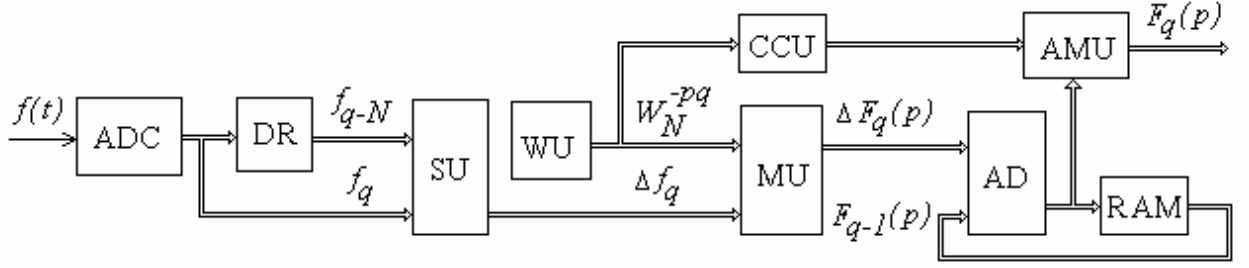

Fig. 3

Besides that, this algorithm has a remarkable peculiarity which permits one to organize HSA so that one complex multiplication may be used for computing two, four and even eight (for complex signals) spectrum harmonics at once [3-6, 27]. This may be done as follows. Let algorithm (4) is presented as follows:

$$F_q(p) = F_{q-1}(p) + \Delta F_q(p), \quad p \in \overline{0, P-1}, \quad q = 0, 1, 2, \dots, \quad (5)$$

$$\Delta F_q(p) = \frac{1}{N} [f(q) - f(q-N)] \exp \left[-j \frac{2\pi}{N} pq \right]. \quad (6)$$

The spectrum increments $\Delta F_q(p)$ may be used not only for spectrum harmonic p , but also for spectrum harmonics

$$p_i = iN/4 + p, \quad i \in \overline{1, 3} \quad (7)$$

and

$$p_k = kN/4 - p, \quad k \in \overline{1, 4}, \quad (8)$$

as well, using known properties of the complex exponential function. In summarized (and simplified) view algorithm (5) modification may be presented as follows:

a) for harmonics of the form (7)

$$F_q(p_i) = F_{q-1}(p_i) + (-j)^{iq} \Delta F_q(p), \quad q = 0, 1, 2, \dots, \quad (9)$$

b) for harmonics of the form (8)

$$F_q(p_k) = F_{q-1}(p_k) + (-j)^{kq} \Delta F_q(-p), \quad q = 0, 1, 2, \dots, \quad (10)$$

where $\Delta F_q(-p)$ are complex conjugated spectrum increments $\Delta F_q(p)$, if the signal samples are real, and if the signal samples are complex, $\Delta F_q(-p)$ are generated by inverting the signs of the products of the signal increments $\Delta f_q = \frac{1}{N} [f(q) - f(q-N)]$ with the imaginary part of the weighting function and then forming the appropriate algebraic sums.

Implementing algorithms (9) and (10) devices are presented in [28-32] and their generalized functional diagram is shown in Fig. 4, where SW are switching components, m is the number of additional subranges, $m \in \{1,3,7\}$.

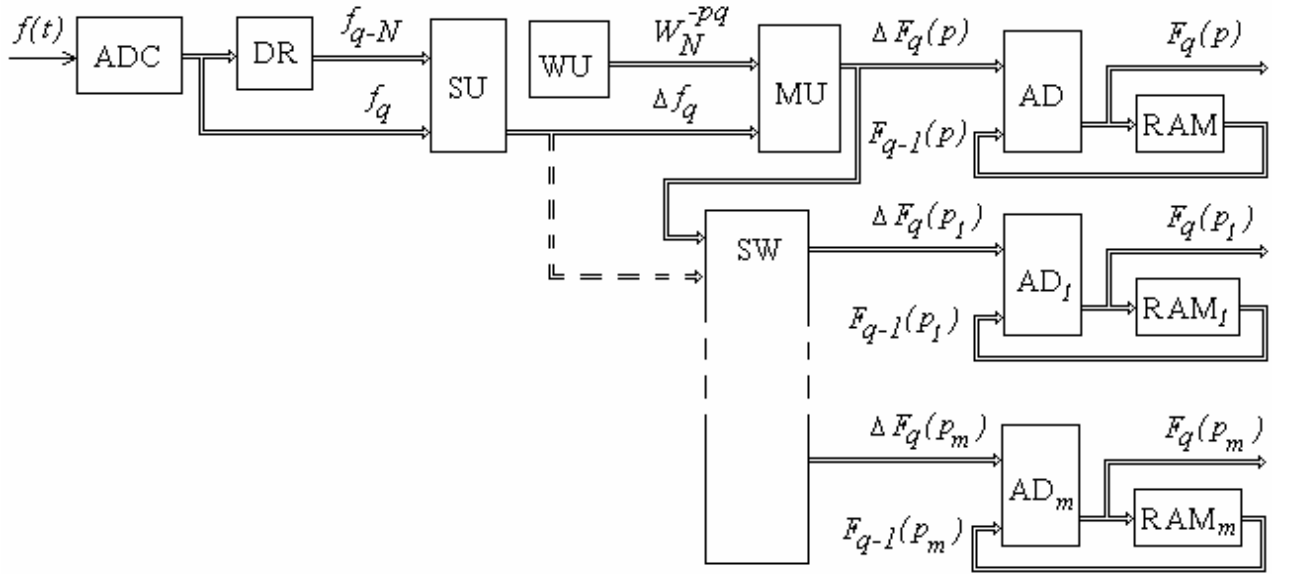

Fig. 4

In the simplest case of complex signal analysis ($P = N$), the harmonic range is partitioned into two subranges $p \in \overline{0, N/2 - 1}$, and by (7) for $i = 2$ we have $p_2 = N/2 + p$. Then by (9) the readouts for the harmonics p_2 are determined as follows:

$$F_q(p_2) = F_{q-1}(p_2) + (-1)^q \Delta F_q(p), \quad (11)$$

i.e., the spectrum increment $\Delta F_q(p)$ for harmonic p obtained at the MU output are fed through SW to the input of the adder for subrange p_2 . In SW, as we see from (11), the sign of the increments $\Delta F_q(p)$ are either preserved or inverted, depending on the parity of the readout index q . To this end, it is sufficient to include in SW two operand sign control units (for the real and imaginary components of $\Delta F_q(p)$), which are controlled by the binary signal from the output of the least significant bit in the q -counter [28]. Operand sign control can be performed by exclusive OR circuits. Simultaneous evaluation of two harmonics doubles the functional speed at a small additional hardware cost.

Using (7) and dividing the harmonic range into four (for a complex signal) or two (for a real signal) subranges, we can similarly design appropriate analyzer structures [29, 30]. In this case, SW, in addition to operand sign control unit, also contains multiplexers for the operations $(-j)^{iq} \Delta F_q(p)$. The activation sequence of

these multiplexers jointly with the corresponding operand sign control circuits can be determined from the data in Table 1, which gives the dependences of the increments $\Delta F_q(p_1)$, $\Delta F_q(p_2)$, and $\Delta F_q(p_3)$ on $\Delta F_q(p)$ and q .

We see from Table 1 that the multiplexer control signal can be taken from the output of the least significant bit of the q -counter, while the control signals for the operand sign control circuits can be provided either by the outputs of the two least significant bits of this counter or by their logical XOR.

TABLE 1

$q \bmod 4$	$\Delta F_q(p_1)$	$\Delta F_q(p_2)$	$\Delta F_q(p_3)$
0	$\Delta F_q(p)$	$\Delta F_q(p)$	$\Delta F_q(p)$
1	$Im \Delta F_q(p) - j Re \Delta F_q(p)$	$-\Delta F_q(p)$	$-Im \Delta F_q(p) + j Re \Delta F_q(p)$
2	$-\Delta F_q(p)$	$\Delta F_q(p)$	$-\Delta F_q(p)$
3	$-Im \Delta F_q(p) + j Re \Delta F_q(p)$	$-\Delta F_q(p)$	$Im \Delta F_q(p) - j Re \Delta F_q(p)$

The HSA speed can be further doubled if in addition to (7) we also use (8). In this case, SW must include also components that generate the spectrum increments $\Delta F_q(-p)$ (10). Moreover, the second SW input should receive from the SU the signal readout increments Δf_q (dashed line in Fig. 4), which are needed for organizing simultaneous processing in corresponding subranges of operands of the harmonics $(2i+1)N/8$ and $kN/4$, $i \in \overline{1,3}$, $k \in \overline{1,4}$.

To explain the technique, Tables 2 and 3 list the indices of simultaneously determined harmonics for real [31] and complex [32] signals. With this determination of the harmonic $p = N/8$, $\Delta F_q(p)$ are used to determine the harmonics $(2i+1)N/8$, $i \in \overline{1,3}$, and Δf_q are used at the same time to calculate the harmonics $kN/4$, $k \in \overline{1,4}$.

TABLE 2

Subrange	Indices of simultaneously determined harmonics				
	1	2	...	N/8-1	N/8
p	N/4-1	N/4-2	...	N/8+1	N/4
p_1	N/4+1	N/4+2	...	3N/8-1	3N/8
p_3	N/2-1	N/2-2	...	3N/8+1	0

TABLE 3

Subrange	Indices of simultaneously determined harmonics				
p	1	2	...	$N/8-1$	$N/8$
p_1	$N/4-1$	$N/4-2$...	$N/8+1$	$N/4$
p_2	$N/4+1$	$N/4+2$...	$3N/8-1$	$3N/8$
p_3	$N/2-1$	$N/2-2$...	$3N/8+1$	$N/2$
p_4	$N/2+1$	$N/2+2$...	$5N/8-1$	$5N/8$
p_5	$3N/4-1$	$3N/4-2$...	$5N/8+1$	$3N/4$
p_6	$3N/4+1$	$3N/4+2$...	$7N/8-1$	$7N/8$
p_7	$N-1$	$N-2$...	$7N/8+1$	0

Structural diagrams of analyzers based on algorithms (9) and (10) are given in the invention descriptions [28-32]. These analyzers using modern hardware components and involving some additional hardware costs expand the frequency range by two, four, or eight times. The additional hardware costs increase much slowly than the incremental benefit produced by the group complex multiplication.

IV. MULTICHANNEL MATCHED FILTERING ON THE BASIS OF HSA

HSA may be used for FIR-filtering [33] in invariant to information shift (stationary) mode. Such filters perform signal convolution with a given impulse response

$$s(\tau) = \int_{\tau-T}^{\tau} f^*(t)g(t-\tau)dt = \int_0^T f^*(t+\tau)g(t)dt, \quad (12)$$

which, in accordance to Parseval theorem, is equivalent to the integral

$$s(\tau) = \frac{1}{2\pi} \int_{-\infty}^{\infty} F_{\tau}(\omega)G^*(\omega)d\omega, \quad (13)$$

where $G(\omega)$ is the unshifted impulse response spectrum, and $F_{\tau}(\omega)$ is the signal sliding spectrum in the analysis interval T . The result of FIR-filtering (13) may be presented by the discrete expression as follows

$$r(q) = \sum_{p=0}^{P-1} F_q(p)G^*(p), \quad (14)$$

where $F_q(p)$ and $G^*(p)$ are discrete equivalents of the spectra $F_{\tau}(\omega)$ and $G^*(\omega)$, P is the number of used impulse response spectrum readouts. The expression (14) is equivalent to the traditional determination of the discrete correlation convolution

$$r(q) = \sum_{k=0}^{N-1} f(k+q)g(k). \quad (15)$$

The expression (14) is the formal description of the FIR-filtering algorithm on the basis of HSA [22]. Practical realization of the filtration procedure while processing with the set of D different impulse responses may be performed by the device, functional diagram of which is shown in Fig. 5, where HSA is a harmonic sliding analyzer; MU_i are multipliers, $i \in \overline{1, D}$; $ROM_G^*_i$ are complex conjugated transfer function ROMs of the spectral readouts for the appropriate filter channels; AA_i are accumulating adders of the pair products.

In such a device mutually overlapped input signal readouts series are transformed, with the help of HSA, to the continuously developing in time and following with interval Δt sliding spectrum readouts series $F_q(p)$, $q=0, 1, 2, \dots$. The series $F_q(p)$ are put simultaneously to all the MU_i first inputs. To the MU_i second inputs outputs of the $ROM_G^*_i$ are connected, which, synchronously with each p -th harmonic readout of the sliding spectrum, present respect p -th harmonic readout of the complex conjugated transfer function spectrum. The products from the MU_i outputs are put to AA_i inputs, which, to the ends of each step of sliding, form the sum (14) of the readouts $r_i(q)$.

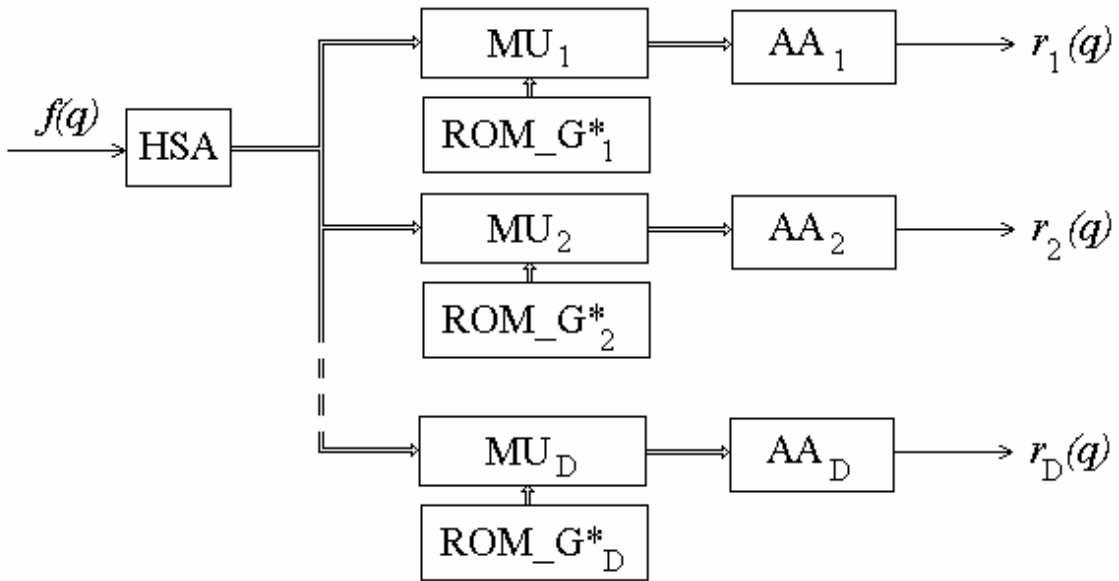

Fig. 5

As it follows from Fig. 5, each channel of filtering consists of one accumulating adder, one $ROM_G^*_i$, and one multiplier connected to the common output of the HSA. The channel structure does not differ from each other. The difference is determined by the contents of the transfer function spectral readouts $ROM_G^*_i$.

The concrete performances of the appropriate devices for multichannel filtering on the basis of HSA are given in [20] for real signals and [21] for complex signals.

As a criterion of effectiveness of the discussed multichannel filter on the basis of HSA may be the number of complex multiplications used for realization of one step of sliding on the set of D channels of filtering. In accordance with the algorithm (14) and the structure of the complex multichannel filter the number α_s of the complex multiplications operations while realization of one step of sliding is determined by the sum of operations in the first stage of processing (stage of computing the sliding spectrum) and operations in the second stage of processing (D times of weighting and summation of the spectral components). Thus,

$$\alpha_s = P + DP = P(1 + D).$$

The appropriate computing expenditure while realization of the standard correlation procedure of the complex multichannel filtering (15) is $\alpha_c = DN$.

Consequently, the benefit in the effectiveness of the multichannel filtering on the basis of HSA may be estimated as the ratio of the computing expenditures

$$B = \frac{\alpha_c}{\alpha_s} = \frac{DN}{P(1 + D)}. \quad (16)$$

Obviously, the more N and the less P , compared with N , the more advantage of filtering on the basis of HSA. It is possible to show that in the case of the matched (optimal) filtering the number P practically coincides with the base of the useful signal $Q = \Delta FT$. The most benefit takes place in the case of realization of the matched filtering of simple ($P=1$) signals, when the filter degenerates into D independent digital resonators. In this case, if $N \gg D$

$$B_{max} = \frac{DN}{1 + D} \approx N. \quad (17)$$

As far as order of the realized filter or base of the filtered signal increases (P increases) the relative benefit lowers. In the limits, when $P = N$

$$B_{min} = \frac{D}{1 + D} \approx 1, \quad (18)$$

and the effectiveness of the digital filter on the basis of HSA practically does not differ from the effectiveness of correlation filter.

It is important to note that the decreasing of the computing expenditure, when using HSA, leads to almost proportional decreasing of the used hardware volume. For example, when realizing of D -channel filter on the basis of correlation convolution (15) it is necessary to use D multipliers and adders working in parallel, speed of each of them is determined by the necessity to perform N multiplications and additions for a one sliding step. When realizing multichannel filter on the basis of HSA the number of used multipliers and adders with the same productivity may be decreased

approximately by N/P times, because in the each channel it is performed only P multiplications and additions. In the utmost case when organizing D digital resonators ($P=1$) it is sufficient to use the only multiplier in the HSA, since the secondary processing in each channel is completely degenerates and the HSA itself is served as the multichannel filter.

While filtering simple and low complexity signals in the conditions of high degree a priori frequency uncertainty, when $N \gg P$, multichannel filter on the basis of HSA has advantages on hardware expenditures not only in comparing with correlation FIR-filter but in comparing with very effective filter on the basis of FFT [33] as well.

The known multichannel filtering devices contain a direct Fourier transform unit, output of which is connected with D filtering channels, each of them consists of a weighting unit and an inverse Fourier transform unit. These devices without special buffer memory units form the readouts of the filtering signal irregularly in time, which distorts the time scale and regularity of the output information. To achieve stationary mode of the filtration such devices require additional hardware expenditures. Furthermore, presence in each channel of such complex unit as an inverse Fourier transform unit increases weight, volume, and cost of the hardware. Devices [20, 21], which realize the discussed algorithm of filtration, are free of the mentioned above drawbacks.

V. RECOMENDATION ON HARMONIC SLIDING ANALYSIS REALIZATION

Note, it's possible another way to the instant spectrum digital analyzers increasing speed of response, viz., using table multiplication [34]. This way may be used as well, if there is enough memory for appropriate tables.

As an A-D converter with the aim to increase the accuracy may be used converter [35] together with Sample-Hold circuit [36] that allows increasing both the accuracy and the speed. Developed project [37] showed that it is possible to reach the accuracy of 16 bits with the sampling frequency up to 2 MHz. Projects [38] and [39] showed that using Xilinx's PLAs Virtex-2 [40] it is possible to implement inventions [31] and [32] with the sampling frequency up to 3.9 MHz for the size of processing extracts $N = 256$ and the accuracy of 8 bits.

Spectrum digital analyzers output only Cartesian constituents of the spectrum complex samples. If there is necessity to obtain modulus of the samples it is possible to increase speed of response by using approximating methods of modulus calculations which use only comparison, shift and summation [41, 42].

REFERENCES

- [1] V.N. Plotnikov, A.V. Belinsky, V.A. Sukhanov and Yu.N. Zhigulevtsev, "Spectrum digital analyzers," Moscow: Radio i svjaz', 1990. – 184 p. (In Russian).
- [2] I.Daubechies, "The wavelet transform, time-frequency localization and signal analysis," IEEE Trans.Inform. Theory, vol.36, No.5, pp.961-1005, 1990.
- [3] V.Ya. Krakovsky, "Algorithms for increase of speed of response for digital analyzers of the instant spectrum," Kibernetika, No.5, pp.113-115, 1990. (In Russian).
- [4] V.Ya.Krakovskii. "Generalized representation and implementation of speed-improvement algorithms for instantaneous spectrum digital analyzers." Cybernetics and System Analysis, Vol.32, No.4, pp.592-597, March 1997.
- [5] V.Ya.Krakovsky. "Spectrum Sliding Analysis Algorithms & Devices." Proceedings of the 1st International Conference on Digital Signal Processing and Its Application, June 30 - July 3, 1998, Moscow, Russia, Volume I, pp.104-107.
- [6] V.Ya.Krakovsky. "Harmonic Sliding Analysis Problem." Twentieth Century Harmonic Analysis - A Celebration, Edited by James S.Byrnes, NATO Science Series, II. Mathematics, Physics and Chemistry - Vol. 33, 2000, p. 375-377.
- [7] V.I. Chajkovsky, "Spectrum experimental analysis metrology peculiarities," Kiev, 1977. – 41 p. – (Preprint/Ukraine SSR NAS Institute of Cybernetics; 77-6). (In Russian).
- [8] V.I. Chajkovsky and V.Ya. Krakovsky, "Sliding spectrum discrete-analog analyzer." USSR Author Certificate 666488 June 5, 1979.
- [9] V.Ya.Krakovsky, "Instant spectrum discrete-analog analyzer." USSR Author Certificate 834576 May 30, 1981.
- [10] V.I. Chajkovsky, "Real time spectrum digital analyzers functional peculiarities," Kiev, 1976. – 32 p. – (Preprint/Ukraine SSR NAS Institute of Cybernetics; 76-39). (In Russian).
- [11] J.W.Cooley and J.W.Tukey, "An algorithm for the machine calculation of complex Fourier series," Math.Comput., vol.19, pp.297-301, 1965.
- [12] J.H. Halberstein, "Recursive, complex Fourier analysis for real-time applications," Proc.IEEE, vol.54, p.903, 1966.
- [13] V.I. Chajkovsky, V.F. Koval', V.Ya. Krakovsky and V.S. Pikulin, "Fourier spectrum analyzer." USSR Author Certificate 560232 May 30, 1977.
- [14] V.I. Chajkovsky, V.Ya. Krakovsky and .F. Koval', "Fourier spectrum digital analyzer." USSR Author Certificate 614440 July 5, 1978.
- [15] G. M. Dillard, "Method and apparatus for computing the discrete Fourier transform recursively." USA Patent 4023028 May 10, 1977.
- [16] V.Ya. Krakovsky, "Development and investigation of specialized computing devices for electrical signals spectrum sliding analysis." Eng. Sci. Cand. Dissertation, NAS Institute of Cybernetics, Kiev, 1980. (In Russian).
- [17] V.Ya. Krakovsky and V.I. Chajkovsky, "Spectrum sliding analysis peculiarities," Autometrija, No.6, pp.34-37, 1984. (In Russian)
- [18] V.Ya. Krakovsky, "Selection of sliding spectrum digital analyzer twiddle factors word size," Izmeritel'naja tekhnika, No.10, pp.13-14, 1983. (In Russian).
- [19] D.A.Perreault and T.C.Rich, "Method and apparatus for suppression of error accumulation in recursive computation of a discrete Fourier transform." USA Patent 4225937 Sep. 30, 1980.
- [20] V.I. Chajkovsky and V.Ya. Krakovsky, "Multichannel filter." USSR Author Certificate 995282 Feb. 7, 1983.
- [21] V.I. Chajkovsky and V.Ya. Krakovsky, "Multichannel filter." USSR Author Certificate 1193778 A Nov. 11, 1985.

- [22] V.I. Chajkovsky and V.Ya. Krakovsky, "Signal discrete filtration on the basis of spectrum sliding analysis." *Kibernetika i vychislitel'naja tekhnika*. – Kiev: Naukova dumka, 1986, N 71. – P. 55-58.
- [23] R.D. Lejtes and V.N. Sobolev, "Synthetic telephone systems digital modeling." Moscow: Svjaz', 1969. (In Russian).
- [24] J.W.Schmitt and D.L.Starkey, "Continuously updating Fourier coefficients every sampling interval." USA Patent 3778606 Dec.11, 1973.
- [25] V.Ya. Krakovsky and V.F. Koval', "Instant spectrum digital analyzer." USSR Author Certificate 932419 May 30, 1982.
- [26] V.Ya. Krakovsky and V.F. Koval', "Instant spectrum digital analyzer." USSR Author Certificate 1095093 A May 30, 1984.
- [27] V.Ya. Krakovskii, "Digital analyzers for dynamic spectral analysis." *Meas. Tech. (USA)*, vol.36, no.12, p.1324-30. Translation of: *Izmer.Tekh. (Russia)*, vol.36, no.12, p.13-16 (Dec.1993).
- [28] V.Ya. Krakovsky and V.F. Koval', "Instant spectrum digital analyzer." USSR Author Certificate 1377762 A2 Feb. 29, 1988.
- [29] V.Ya. Krakovsky and V.F. Koval', "Complex signal instant spectrum digital analyzer." USSR Author Certificate 1406507 A2 June 30, 1988.
- [30] V.Ya. Krakovsky and V.F. Koval', "Instant spectrum digital analyzer." USSR Author Certificate 1456904 A2 Feb. 7, 1989.
- [31] V.Ya. Krakovsky, V.F. Koval', Z.A. Kuznetsova and V.V. Eres'ko, "Real signal instant spectrum digital analyzer." USSR Author Certificate 1563408 A2. – Permission to publication N 267/22, 28.11.91.
- [32] V.Ya. Krakovsky, V.F. Koval', Z.A. Kuznetsova and V.V. Eres'ko, "Complex signal instant spectrum digital analyzer." USSR Author Certificate 1568732 A2. – Permission to publication N 267/22, 28.11.91.
- [33] L.R.Rabiner, B.Gold, "Theory and application of digital signal processing," Prentice-Hall, Inc. Englewood Cliffs, New Jersey 1975.
- [34] V.N. Sobolev, "Dynamic spectral analysis fast algorithm," All-Union ARSO-16 seminar reports abstracts. – Moscow State University, 1991. – P. 232-233. (In Russian).
- [35] V.I. Chajkovsky, V.Ya. Krakovsky and V.F. Koval', "A-D converter." USSR Author Certificate 1401608 A2 May 7, 1988.
- [36] V.Ya. Krakovsky, "Sample-Hold circuit." USSR Author Certificate 1185398 A Oct. 15, 1985.
- [37] L.S. Litovchenko, "Computer system for precise measurement of analog signals: Diploma project" / Project leader V.Ya. Krakovsky. – Kyiv: National Aviation University, 2003. (In Ukrainian).
- [38] P.V. Sergienko, "Real signal instant spectrum digital analyzer in the information processing systems: Diploma project" / Project leader V.Ya. Krakovsky. – Kyiv: National Aviation University, 2003. (In Ukrainian).
- [39] S.V. Smetaniuk, "Complex signal instant spectrum digital analyzer in the information processing systems: Diploma project" / Project leader V.Ya. Krakovsky. – Kyiv: National Aviation University, 2003. (In Ukrainian).
- [40] <http://www.xilinx.com>
- [41] V.Ya. Krakovsky, "Complex quantities modulus approximate determination." *Metrology*. – 1983. – No 4. – P. 7-10. (In Russian).
- [42] V.Ya. Krakovsky, "Complex quantities modulus approximate determination errors." *Metrology*. – 1992. – No 4. – P. 25-30. (In Russian).